



**NOTICE OF A REGULAR MEETING TO BE HELD BY THE  
McALLEN PUBLIC UTILITY BOARD OF TRUSTEES**

**DATE:** Tuesday, February 11, 2025

**TIME:** 4:00 P.M.

**PLACE:** McAllen City Hall  
Commission Chambers – 3<sup>rd</sup> Floor  
1300 Houston Avenue  
McAllen, Texas 78501

**SUBJECT MATTER:**

**See Subsequent Agenda.**

**CERTIFICATION**

I, the Undersigned authority, do hereby certify that the attached agenda of meeting of the McAllen Public Utility Board of Trustees is a true and correct copy and that I posted a true and correct copy of said notice on the bulletin board in the Municipal Building, a place convenient and readily accessible to the general public at all times, and said Notice was posted on the 7th day of February, 2025 at 3:00 P.M. and will remain so posted continuously for at least 72 hours preceding the scheduled time of said meeting in accordance with Chapter 551 of the Texas Government Code.

  
Cynthia Salinas  
Utility Board Secretary



**BOARD OF TRUSTEES MEETING  
TUESDAY, FEBRUARY 11, 2025 – 4:00 PM  
MCALLEN CITY HALL - 3RD FLOOR  
1300 HOUSTON AVE, MCALLEN, TX 78501**

## **AGENDA**

**AT ANY TIME DURING THE COURSE OF THIS MEETING, THE MCALLEN PUBLIC UTILITY BOARD MAY RETIRE TO EXECUTIVE SESSION UNDER TEXAS GOVERNMENT CODE 551.071(2) TO CONFER WITH ITS LEGAL COUNSEL ON ANY SUBJECT MATTER ON THIS AGENDA IN WHICH THE DUTY OF THE ATTORNEY TO THE MCALLEN PUBLIC UTILITY BOARD UNDER THE TEXAS DISCIPLINARY RULES OF PROFESSIONAL CONDUCT OF THE STATE BAR OF TEXAS CLEARLY CONFLICTS WITH CHAPTER 551 OF THE TEXAS GOVERNMENT CODE. FURTHER, AT ANY TIME DURING THE COURSE OF THIS MEETING, THE MCALLEN PUBLIC UTILITY BOARD MAY RETIRE TO EXECUTIVE SESSION TO DELIBERATE ON ANY SUBJECT SLATED FOR DISCUSSION AT THIS MEETING, AS MAY BE PERMITTED UNDER ONE OR MORE OF THE EXCEPTIONS TO THE OPEN MEETINGS ACT SET FORTH IN TITLE 5, SUBTITLE A, CHAPTER 551, SUBCHAPTER D OF THE TEXAS GOVERNMENT CODE.**

### **CALL TO ORDER**

### **PLEDGE**

### **INVOCATION**

### **1. MINUTES:**

- a) Approval of Minutes held January 28, 2025

### **2. CONSENT AGENDA:** *(All matters listed under Consent Agenda are considered to be routine by the Governing Body and will be enacted by one motion. There will be no separate discussion of these items; however, if discussion is desired, that item(s) will be removed from the Consent Agenda and will be considered separately.)*

- a) Approval of Nelson Addition Lots 5A and 6A Subdivision (2-lot, Residential)

### **3. ORDERS:**

- a) Order amending the budget of the McAllen Public Utility Board of Trustees for Fiscal Year 2024-2025 for an increase in expenditures within the Water Depreciation Fund.

### **4. MANAGER'S REPORT:**

- a) Consideration and Possible Action to write-off the 3rd quarter bad debt fiscal year 2023-2024.

### **5. FUTURE AGENDA ITEMS**

### **6. EXECUTIVE SESSION, CHAPTER 551, TEXAS GOVERNMENT CODE, SECTION 551.071 CONSULTATION WITH ATTORNEY, SECTION 551.072 LAND TRANSACTION, SECTION 551.074 PERSONNEL MATTERS; SECTION 551.087 ECONOMIC DEVELOPMENT NEGOTIATIONS**

- a) Consultation with City Attorney regarding pending litigation Tex. Gov't Code Sec. 551.071

## **ADJOURNMENT**

**IF ANY ACCOMMODATION FOR A DISABILITY IS REQUIRED (OR INTERPRETERS FOR THE DEAF), NOTIFY UTILITY ADMINISTRATION (681-1630) FORTY-EIGHT (48) HOURS PRIOR TO THE MEETING DATE. WITH REGARD TO ANY ITEM, THE MCALLEN PUBLIC UTILITY BOARD OF TRUSTEES MAY TAKE VARIOUS ACTIONS; INCLUDING BUT NOT LIMITED TO RESCHEDULING AN ITEM IN ITS ENTIRETY FOR A FUTURE DATE OF TIME. THE MCALLEN PUBLIC UTILITY BOARD MAY ELECT TO GO INTO EXECUTIVE SESSION ON ANY ITEM WHETHER OR NOT SUCH ITEM IS POSTED AS AN EXECUTIVE SESSION ITEM AT ANY TIME DURING THE MEETING WHEN AUTHORIZED BY THE PROVISIONS OF THE OPEN MEETINGS ACT.**

**THE NEXT REGULARLY SCHEDULED BOARD MEETING WILL BE HELD ON FEBRUARY 25, 2025.**



|                             |                       |                    |
|-----------------------------|-----------------------|--------------------|
|                             | <b>AGENDA ITEM</b>    | <b><u>1.a.</u></b> |
| <b>PUBLIC UTILITY BOARD</b> | <b>DATE SUBMITTED</b> | <b>02/03/2025</b>  |
|                             | <b>MEETING DATE</b>   | <b>2/11/2025</b>   |

1. Agenda Item: Approval of Minutes held January 28, 2025

2. Party Making Request:

3. Nature of Request:

4. Budgeted:

|                      |       |                          |       |
|----------------------|-------|--------------------------|-------|
| <b>Bid Amount:</b>   | _____ | <b>Budgeted Amount:</b>  | _____ |
| <b>Under Budget:</b> | _____ | <b>Over Budget:</b>      | _____ |
|                      |       | <b>Amount Remaining:</b> | _____ |

5. Reimbursement:

6. Routing:  
Savannah Arredondo                      Created/Initiated - 2/3/2025

7. Staff's Recommendation:

8. City Attorney: Approve. AWS

9. MPU General Manager: Approved - MAV

10. Director of Finance for Utilities: Approved - MSC

**STATE OF TEXAS  
COUNTY OF HIDALGO  
CITY OF MCALLEN**

The McAllen Public Utility Board (MPUB) convened in a Regular Meeting on **Tuesday, January 28, 2025**, at 4:00 pm at McAllen City Hall, Commission Chambers with the following present:

|         |                        |  |
|---------|------------------------|--|
|         | Charles Amos           | Chairman                                 |
|         | Ernest Williams        | Vice-Chairman                            |
|         | Albert Cardenas        | Trustee                                  |
|         | Javier Villalobos      | Mayor/Ex-Officio                         |
| Absent: | Ricardo Godinez        | Trustee                                  |
| Staff:  | Marco A Vega, P.E.     | General Manager                          |
|         | Juan J. Rodriguez      | Assistant General Manager                |
|         | Austin Stevenson       | City Attorney                            |
|         | Cynthia Salinas        | Utility Board Secretary                  |
|         | Savannah Arredondo     | Assistant to the Utility Board Secretary |
|         | David Garza            | Director of Wastewater Systems           |
|         | Juan Vallejo           | Assistant Director of Water Systems      |
|         | Maria Chavero          | Director of Treasury Management          |
|         | Janet Landeros         | Grants and Contracts Coordinator         |
|         | Erika Gomez, P.E.      | Utility Engineer                         |
|         | Edward Gonzalez        | Director of Water Systems                |
|         | Jim Bob Sides          | Video Production Specialist              |
|         | Gerardo Noriega        | Director of Purchasing and Contract      |
|         | Carlos Gonzalez, P.E., | Utility Engineer                         |
|         | Mario Vela             | Deputy Director Public Works             |
|         | Liza Losoya            | Senior Accounting Clerk                  |
|         | Emmanuel Villa         | Customer Service Specialist              |
|         | Jonathan Lucio         | Wastewater Lab Technician                |
|         | Jasen Garza            | Meter Reader                             |
|         | Lizandro Gonzalez      | Meter Reader                             |
|         | Alexi Ramon De La O    | T&D Crew Leader                          |
|         | Jeremy Cardenas        | T&D Maintenance Worker                   |
|         | Andrea Cantu           | Grant Development Specialist             |
|         | Kobe Marquez           | Grant Development Specialist             |
|         | Ricardo Munion         | Water Plant Operator                     |
|         | Arturo Arriaga         | Water Plant Operator                     |

**CALL TO ORDER:**

Chairman Amos called the meeting to order at 4:11 p.m.

**1. MINUTES:**

- a) Approval of the Minutes for the Workshop and Regular Meeting held January 14, 2025.

Vice-Chairman Williams moved to approve the minutes for the workshop and regular meeting held January 14, 2025. Trustee Cardenas seconded the motion. The motion carried unanimously by those present.

**2. CONSENT AGENDA:**

- a) Consideration and action on approval to purchase John Deere 320P backhoe with accessories through Source well contract #011723-JDC. Project No. 01-25-P28-01
- b) Action to Approve the Purchase of Inductive Coupled Plasma Mass Spectrometry through TXMAS Cooperative (Project No. 01-25-P30-01)
- c) Approval of Aqualina at Tres Lagos Phase IV Subdivison
- d) Approval of Bentsen View Subdivsiion (1 Lot, C-4 Commercial Use)

Mr. Marco Vega, P.E., General Manager, mentioned that all the items on consent agenda met MPU requirements, however, they could be discussed at the pleasure of the board.

Mayor Villalobos moved to approve items 2a through 2d. Trustee Cardenas seconded the motion. The motion carried unanimously by those present.

### **3. BIDS AND CONTRACTS:**

- a) Award of Contracts to Purchase New Current Model MPU Vehicles through Cooperative Pricing. Project No. 12-24-P14-180

Mr. Mario Vela, Deputy Director of Public Works stated the fleet operations of Public Works seeks authorization to award purchases contracts for seven (7) new replacement vehicles for various public utilities departments. On December 19, 2024, Public Works in conjunction with Purchasing and Contracts Department solicited formal bids. A total of eight (8) vendors responded to the bid solicitation. There-for staff recommends award of purchase contracts to Randall Reeds Prestige Ford from Garland Texas for item number 7 and 21, Silsbee Ford from Silsbee Texas for items 4, 5 and 16, and Sames McAllen Ford from McAllen Texas for items 2 and 3. The award of item three (3) is subject to a budget reclassification for amendments. Staff recommends approval.

Trustee Cardenas moved to approve award of contracts to purchase new MPU vehicles. Vice-Chairman Williams seconded the motion. The motion carried unanimously by those present.

- b) Consideration and Approval of TIPS Contract Proposal for the Shary Road Sewer Line Extension (Project No. 01-25-C15-01)

Mr. Carlos Gonzalez, P.E., Director of Utility Engineering stated staff is respectfully requesting Board consideration and approval of a TIPS Contract from Artisan Services Group for the extension of a gravity sewer line and force main adjustment needed along Shary Road in the vicinity of Mile 6 Road. This project was triggered from some TXDOT improvements that are about to commence on Shary Rd. There has been a bit of development in the area. There has been a bit of utility work in conjunction with the developments. There is an ongoing Mile 6 sewer line in the vicinity as well. This is the last bit of infrastructure needed for TXDOT. Their project will commence in the next month. Staff recommends approval of the TIPS Contract for the amount of \$382,535.75.

Trustee Cardenas moved to approve of TIPS Contract for the Shary Road sewer line extension. Vice-Chairman Williams seconded the motion. The motion carried unanimously by those present.

### **4. UTILITY LAYOUTS:**

- a) Sharpless Square; Consideration and Approval of the Revised MPU Participation for Water Public Improvements

Mrs. Erika Gomez, P.E., Assistant Director of Utility Engineering stated with the approval of Sharpless Square Subdivision, the developer requested MPUB participation for off-site water public improvements which includes the installation of an 8" waterline to complete the loop along Trenton Rd, abandon an existing 2" waterline. MPUB approved the request for board participation on May 29, 2024 in the amount of \$15,795.00. During construction, the proposed waterline for the off-site scope of the project was in conflict with a storm sewer system and needed to be realigned to avoid the storm system. This added additional fittings as well as PVC waterline pipe which incurred an adjustment to the original cost estimate. The engineer has submitted a schedule of values and the developer is requesting an amendment to the participation in the amount of \$1,290.00. Bringing the total of reused

participation mount to \$17,085.00. Staff is recommending approval of the revised participation.

Mayor Villalobos moved to approve MPU participation for water public improvements for Sharpless Square. Trustee Cardenas seconded the motion. The motion carried unanimously by those present.

b) Consideration and Approval of participation for sewer improvements for Sharyland Business Park No. 10 Subdivision

Mrs. Erika Gomez, P.E., Assistant Director of Utility Engineering stated this subdivision is located on Shary Rd and approximately 1,800 ft. South of Military HWY. The subdivision was presented and approved on June 14, 2022. As part of the subdivision improvements, a forcemain was required to cross a drainage ditch. The original plans included the installation under the proposed drainage. An installation would have excessive depth and higher probability of clogging thus resulting in higher long-term maintenance by wastewater operations department. Staff advised the contractor to pursue the installation of an aerial crossing as illustrated in exhibits attached to the memo. The developer has requested cost participation for this change in scope for the amount of \$34,550 which will cover the cost of the steel casing and the concrete support. Staff recommends approval of participation in the amount of \$34,550 to the developer of Sharyland Business Park No. 10.

Mayor Villalobos moved to approve of participation for sewer improvements for Sharyland Business Park No. 10 Subdivision. Vice-Chairman Williams seconded the motion. The motion carried unanimously by those present.

**5. MANAGER'S REPORT:**

a) Review of Quarterly Investment Report for Quarter Ending June 30, 2024

Ms. Maria Chavero, Director of Treasury Management stated the quarterly investment report was presented to the audit and investment committee meeting on January 9<sup>th</sup> and were prepared according to our policy and in performance with the public funds investment act. Staff recommends the acceptance of report as presented.

Trustee Cardenas moved to accept the quarterly investment report for quarter ending June 30, 2024. Vice-Chairman Williams seconded the motion. The motion carried unanimously by those present.

**6. FUTURE AGENDA ITEMS**

Marco Vega, General Manager stated the annual board retreat will be held on Thursday, February 27, 2025 at the South Wastewater Treatment Plant.

**8. EXECUTIVE SESSION, CHAPTER 551, TEXAS GOVERNMENT CODE, SECTION 551.071 CONSULTATION WITH ATTORNEY, SECTION 551.072 LAND TRANSACTION, SECTION 551.074 PERSONNEL MATTERS; SECTION 551.087 ECONOMIC DEVELOPMENT NEGOTIATIONS**

Chairman Amos recessed the meeting at 4:15 p.m. to go into Executive Session. Chairman Amos reconvened the meeting around 4:34 p.m.

a) Consultation with City Attorney regarding pending litigation Tex. Gov't Code Sec. 551.071.

No Action

**ADJOURNMENT**

There being no other business to come before the Board, the meeting was unanimously adjourned at 4:36 p.m.

---

Charles Amos, Chairman

Attest:

---

Cynthia Salinas  
Utility Board Secretary



**AGENDA ITEM** 2.a.

**PUBLIC UTILITY BOARD**

**DATE SUBMITTED** 02/03/2025

**MEETING DATE** 2/11/2025

1. **Agenda Item:** Approval of Nelson Addition Lots 5A and 6A Subdivision (2-lot, Residential)

2. **Party Making Request:**  
Erika Gomez, Developmental Activities

3. **Nature of Request:** Request of MPUB Approval from the developer of the proposed subdivision

4. **Budgeted:**

|                      |       |                          |       |
|----------------------|-------|--------------------------|-------|
| <b>Bid Amount:</b>   | _____ | <b>Budgeted Amount:</b>  | _____ |
| <b>Under Budget:</b> | _____ | <b>Over Budget:</b>      | _____ |
|                      |       | <b>Amount Remaining:</b> | _____ |

5. **Reimbursement:** N/A

6. **Routing:**  
Erika Gomez                      Created/Initiated - 2/3/2025

7. **Staff's Recommendation:** Approval of subdivision as conditions set forth

8. **City Attorney:** Approve. AWS

9. **MPU General Manager:** Approved - MAV

10. **Director of Finance for Utilities:** Approved - MSC

# Memo

**TO:** Marco A. Vega, P.E., General Manager  
J.J. Rodríguez, Asst. General Manager

**FROM:** Erika Gomez, P.E., Utility Engineer

**DATE:** February 03, 2025

**SUBJECT:** **Nelson Addition Lots 5A & 6A Subdivision; Consideration and Approval**

---

This property is located approximately 700 ft east of Bentsen Rd along the South side of HWY 83. It is located within the McAllen City Limits and within MPU's Water and Wastewater CCN. The tract consists of 0.143 acres and is being proposed as R-3, Townhomes.

The subdivision application was originally filed with the City on June 21, 2024 and received preliminary P&Z approval on September 20, 2024. The information required from the developer's engineer for this agenda was received on January 23, 2025.

Utility plan/availability is described as follows:

1. **Water Service:** The applicant is proposing to connect to an existing 2-inch waterline along Ithaca Ave and connect a water service. This property is located in the downtown area, where fire protection is limited. While a fire hydrant is required, due to the scale of this project and the overall benefit to the surrounding area, MPU will install the hydrant at a nearby location to meet fire protection requirements.
2. **Wastewater Service:** The applicant proposes to keep the existing sewer service that its servicing lot 5A and lot 6A. Existing sewer services are connect to the 21" sewerline along 16<sup>th</sup> Street.
3. Developer has submitted a Reimbursement Waiver

**Staff recommend MPUB approval of the subdivision application as proposed subject to the following: 1.) Dedication of a utility easement, possibly along the perimeter of the property, and where the main utility lines will be installed; 2.) Installation of the proposed public utility infrastructure be constructed as proposed, 3.) Installation of a Fire Hydrant by McAllen Public Utility**

I'll be available for further discussion/questions at the MPUB meeting.



---

Engineering Firm Reg # 10602    Surveying Firm Reg # 101416-00  
200 S. 10<sup>th</sup> Street, Suite 1500, McAllen, Texas 78501    Phone: (956) 702-8880    Fax: (956) 702-8883

## **Nelson Addition Lots 5A and 6A Subdivision Utility Narrative**

**To:** Erika Gomez, P.E. (McAllen Public Utilities)  
**From:** Saul D. Maldonado, P.E.  
**Date:** January 16, 2025  
**Re:** Nelson Addition Lots 5A and 6A Subdivision

---

Below is a brief summary for the above-mentioned project to date:

Sewer:

- There is an existing 21" sanitary sewer main line providing service to Nelson Addition Lots 5A and 6A Subdivision at the front of subdivision, running north to south at the center line of 16<sup>th</sup> street.
- The proposed Nelson Addition Lots 5A and 6A Subdivision will be developed into 2 lots. Lot 5A will be remaining as residential lot, and lot 6A will be a townhome residential. Lot 5A has three existing cleanouts services and lot 6A has one existing cleanout service within a proposed 5 feet utility easement.

Water:

- The existing 2" main waterline line for Nelson Addition Lots 5A and 6A Subdivision is approximately 3 feet offset south from the south boundary line of Nelson Addition Lots 5A and 6A Subdivision going east approximately 150 feet and connected to a 4" waterline running into a 20 feet alley.
- A fire hydrant will be proposed within a 300 feet radius. It will be located approximately 150 feet west from the southwest corner of Nelson Addition Lots 5A and 6A Subdivision and connected with an existing 6" main waterline running north to south within an existing 13 feet alley. Please see Utility Layout for reference and approval.

Please do not hesitate to contact our office should you have any questions or require additional information regarding this project.

Sincerely,

A handwritten signature in blue ink, appearing to read "Saul D. Maldonado".

Saul D. Maldonado, PE.

Project Manager

**SAMES, Inc.**

**REIMBURSEMENT WAIVER**

STATE OF TEXAS           X

COUNTY OF HIDALGO     X

THIS CERTIFICATE, issued by the McAllen Public Utility (MPUB), as authorized by such Board of Trustees, hereinafter called the MPUB to Oscar De La Fuente hereinafter called the DEVELOPER.

(Developer)

1. The DEVELOPER is the developer of the following described property:

Nelson Addition Lots 5A and 6A Subdivision And proposes to construct Utility Improvements as shown on a plan

(Location)

designed by SAMES INC. dated 1/16/2025, hereinafter called the

IMPROVEMENTS, as approved by the McAllen Public Utility Board on \_\_\_\_\_.

2. By the execution of this certificate, the Developer hereby waives and disclaims the right to obtain reimbursement from Intervening Developers in accordance with the MPUB's Reimbursement Policy.

ISSUED in duplicate originals this \_\_\_\_\_ day of \_\_\_\_\_, 20\_\_\_\_\_

CITY OF McALLEN BY THE  
McALLEN PUBLIC UTILITY

BY: \_\_\_\_\_  
Marco A Vega, P.E.  
General Manager  
McAllen Public Utility  
Post Office Box 220  
McAllen, Texas 78505-0220  
(956) 681-1630

ATTEST:

\_\_\_\_\_  
Board Secretary

DEVELOPER

BY: \_\_\_\_\_  
NAME &  
ADDRESS: Oscar De La Fuente (Developer)  
520 E Newport Lane, McAllen, Tx 78501

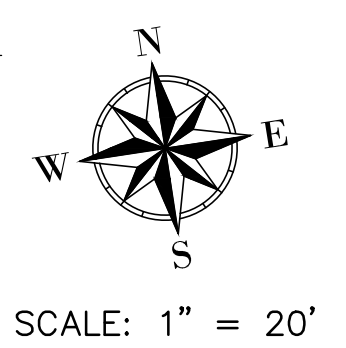
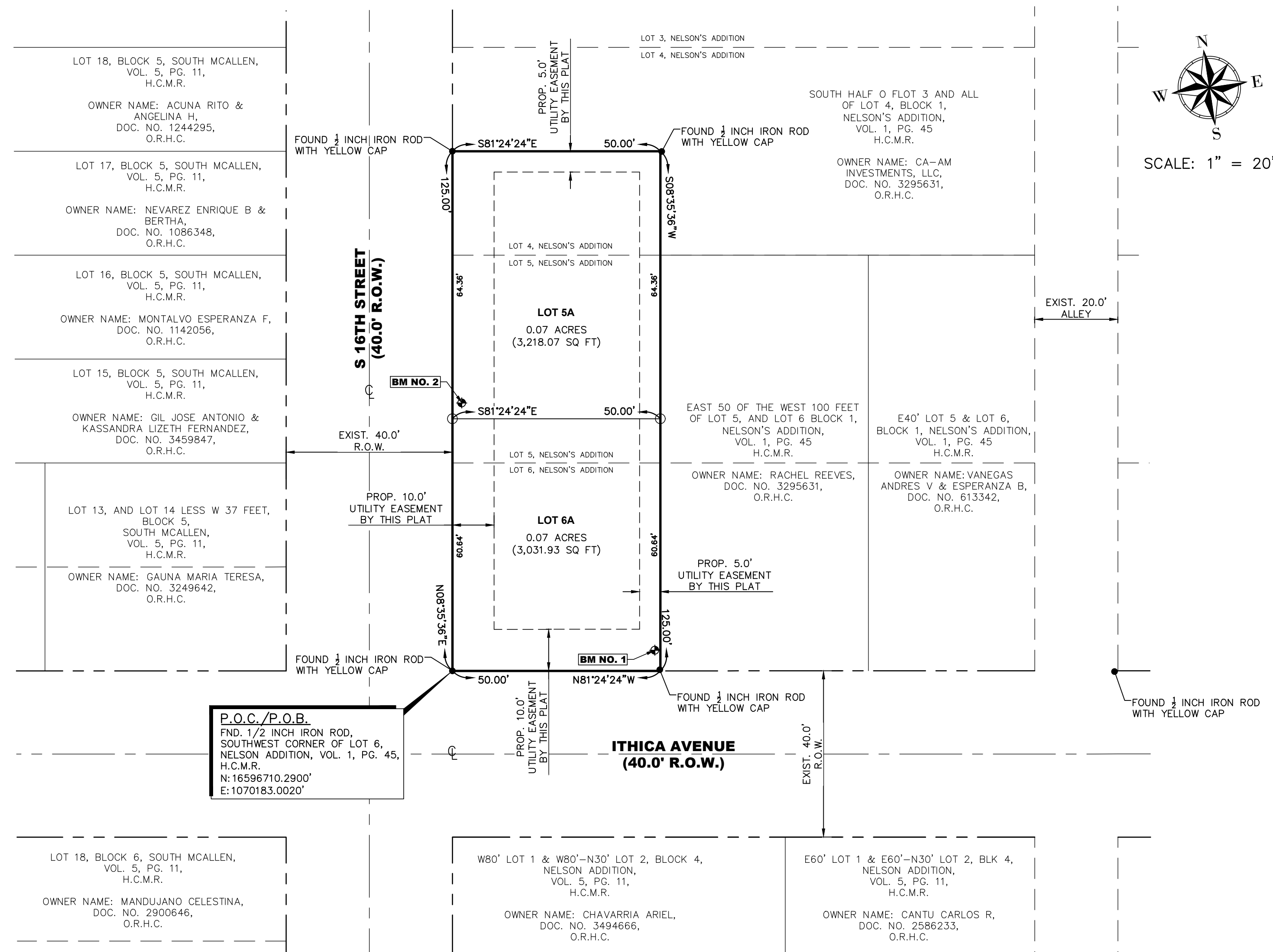

| LEGEND   |   |
|----------|---|
| ●        | - FND. 1/2" IRON ROD W/CAP                |
| ○        | - SET 1/2" IRON ROD W/CAP STAMPED "SAMES" |
| ⊕        | - ON-SITE BENCHMARK                       |
| ⊙        | - CENTER LINE                             |
| H.C.M.R. | - HIDALGO COUNTY MAP RECORDS              |
| H.C.O.R. | - HIDALGO COUNTY OFFICIAL RECORDS         |
| P.O.C.   | - POINT OF COMMENCING                     |
| P.O.B.   | - POINT OF BEGINNING                      |
| PROP.    | - PROPOSED                                |
| ELEV.    | - ELEVATION                               |
| R.O.W.   | - RIGHT OF WAY                            |
| FND.     | - FOUND                                   |

**GENERAL NOTES**

- NO STRUCTURES SHALL BE PERMITTED OVER ANY EASEMENT. "EASEMENTS SHALL BE KEPT CLEAR OF FENCES, BUILDINGS, SHEDS, SHRUBS TREES, AND OTHER PLANTINGS (EXCEPT LOW, LESS THAN 18 INCHES MATURE HEIGHT, GROUND COVER, GRASS OR FLOWERS) AND OTHER OBSTRUCTIONS TO THE OPERATIONS AND MAINTENANCE OF THE EASEMENT." AS PER 54 SECTION 6.2 (d) (6) OF THE SUBDIVISION ORDINANCE.
- SETBACK AS FOLLOWS: (EXCEPT WHERE GREATER SETBACK OR EASEMENT APPLIES) FRONT 16TH STREET..... 10 FEET IN ACCORDANCE WITH THE ZONING ORDINANCE OR IN LINE WITH AVERAGE SETBACKS OF EXISTING STRUCTURES OR GREATER FOR EASEMENTS, WHICHEVER IS GREATER APPLIES. REAR..... 0 FEET IN ACCORDANCE WITH ZONING ORDINANCE, OR GREATER FOR EASEMENTS. SIDES..... 6 FEET IN ACCORDANCE WITH ZONING ORDINANCE, OR GREATER FOR EASEMENTS. GARAGE..... 18 FT. EXCEPT WHERE GREATER SETBACK IS REQUIRED; GREATER SETBACK APPLIES. CORNER..... IN ACCORDANCE WITH ZONING ORDINANCE, OR GREATER FOR EASEMENTS.
- FLOOD INSURANCE RATING: INSURANCE RATE MAP COMMUNITY PANEL NUMBER 480343 0010 C. REVISED NOVEMBER 2, 1982 ZONE C. AREAS OF MINIMAL FLOODING. (NO SHADING)
- BENCHMARK 1: SET IRON ROD, WITH REFERENCE CAP AMERICAN VERTICAL DATUM OF 1988 (NAVD88) NORTHING: 16596707.9300 EASTING: 1070231.8410 ELEVATION: 126.582'
- BENCHMARK 2: SET IRON ROD, WITH REFERENCE CAP AMERICAN VERTICAL DATUM OF 1988 (NAVD88) NORTHING: 16596773.6900 EASTING: 1070194.8190 ELEVATION: 126.524'
- DRAINAGE DETENTION REQUIRED OF 0.0002 AC-FT TO BE DETAINED WITHIN THE SUBDIVISION.
- MINIMUM PERMISSIBLE FINISHED FLOOR ELEVATION SHALL BE 18" ABOVE TOP OF CURB AT MID POINT OF EACH LOT.
- MINIMUM 4 FT. WIDE SIDEWALK REQUIRED ON ITHICA AVENUE AND S 16TH STREET.
- PERIMETER SIDEWALKS MUST BE BUILT OR MONEY ESCROWED IF NOT BUILT AT THIS TIME.
- A 6' FT. OPAQUE BUFFER REQUIRED FROM ADJACENT/BETWEEN MULTI-FAMILY RESIDENTIAL AND COMMERCIAL, AND INDUSTRIAL ZONES/USES.
- A 8 FT. MASONRY WALL REQUIRED BETWEEN SINGLE FAMILY RESIDENTIAL AND COMMERCIAL, INDUSTRIAL, OR MULTI-FAMILY RESIDENTIAL ZONES/USES.
- PERIMETER BUFFERS MUST BE BUILT AT TIME OF SUBDIVISION IMPROVEMENTS.
- NEAREST CITY OF McALLEN BENCHMARK IS MC82. SAID BENCHMARK IS LOCATED APPROXIMATE 100 FEET NORTH OF THE SOUTHWEST CORNER INTERSECTION OF BROADWAY AVENUE AND JACKSON AVENUE, ELEV=125.01 (N=16596351.34, E=1071202.75).
- COMMON AREAS, ANY PRIVATE DRIVES, GATE AREAS, ETC. MUST BE MAINTAINED BY THE LOT OWNERS AND NOT THE CITY OF McALLEN.



**NELSON ADDITION LOTS 5A AND 6A SUBDIVISION**

0.143 (6,250.00 SQ. FT.) OF AN ACRE COMPRISED OF 0.0287 (1,250.00 SQ. FT.) OF AN ACRE OUT OF LOT 4, BLOCK 1, 0.0573 (2,500.00 SQ. FT.) OF AN ACRE OUT OF LOT 5, BLOCK 1, AND 0.0573 (2,500.00 SQ. FT.) OF AN ACRE OUT OF LOT 6, BLOCK 1, NELSON'S ADDITION, AN ADDITION TO THE CITY OF McALLEN, HIDALGO COUNTY, TEXAS, AS PER MAP OR PLAT THEREOF RECORDED IN VOLUME 1, PAGE 45, MAP RECORDS OF HIDALGO COUNTY, TEXAS.

**METES AND BOUNDS**

BEING A 0.143 (6,250.00 SQ. FT.) OF AN ACRE COMPRISED OF 0.0287 (1,250.00 SQ. FT.) OF AN ACRE OUT OF LOT 4, BLOCK 1, 0.0573 (2,500.00 SQ. FT.) OF AN ACRE OUT OF LOT 5, BLOCK 1, AND 0.0573 (2,500.00 SQ. FT.) OF AN ACRE OUT OF LOT 6, BLOCK 1, NELSON'S ADDITION, AN ADDITION TO THE CITY OF McALLEN, HIDALGO COUNTY, TEXAS, AS PER MAP OR PLAT THEREOF RECORDED IN VOLUME 1, PAGE 45, MAP RECORDS OF HIDALGO COUNTY, TEXAS AND BEING MORE PARTICULARLY DESCRIBED BY METES AND BOUNDS, AS FOLLOWS:

COMMENCING; FOUND 1/2 INCH IRON ROD WITH A YELLOW PLASTIC CAP, FOR THE SOUTHWEST CORNER OF LOT 6, BLOCK 1, OF SAID NELSON'S ADDITION, BEING ON THE INTERSECTION OF SIXTEENTH STREET (HAVING A 40.00' R.O.W.) AND NORTH AVENUE (HAVING A 40.00' R.O.W.), FOR THE SOUTHWEST CORNER AND POINT OF BEGINNING, OF THIS HEREIN DESCRIBED TRACT OF LAND, HAVING A GRID COORDINATE OF N=16596710.2900', E=1070183.0020'.

THENCE; NORTH 08°35'36" EAST, ALONG THE WEST LINE OF LOT 6, BLOCK 1, OF SAID NELSON'S ADDITION AND EAST RIGHT OF WAY LINE SIXTEENTH STREET (HAVING A 40.00' R.O.W.), AT A DISTANCE OF 50.00 FEET, TO A POINT, FOR THE COMMON CORNER OF LOT 5 AND LOT 6, BLOCK 1, OF SAID NELSON'S ADDITION, CONTINUING AT A DISTANCE OF 100.00 FEET, TO A POINT, FOR THE COMMON CORNER OF LOT 4 AND LOT 5, BLOCK 1, OF SAID NELSON'S ADDITION, CONTINUING TO A TOTAL DISTANCE OF 125.00 FEET, TO A FOUND 1/2 INCH IRON ROD WITH A YELLOW PLASTIC CAP, FOR THE SOUTHWEST CORNER OF A TRACT OF LAND CONVEYED TO CA-AM INVESTMENTS, L.L.C., AS RECORDED IN DOCUMENT NUMBER 3295631, OFFICIAL RECORDS, HIDALGO COUNTY, TEXAS, AND FOR THE NORTHWEST CORNER OF THIS HEREIN DESCRIBED TRACT OF LAND;

THENCE; SOUTH 81°24'24" EAST, ALONG THE SOUTH LINE OF SAID TRACT OF LAND CONVEYED TO CA-AM INVESTMENTS, L.L.C., A DISTANCE OF 50.00 FEET, TO A FOUND 1/2 INCH IRON ROD WITH A YELLOW PLASTIC CAP, FOR AN INTERIOR CORNER OF SAID TRACT OF LAND CONVEYED TO CA-AM INVESTMENTS, L.L.C., AND FOR THE NORTHEAST CORNER OF THIS HEREIN DESCRIBED TRACT OF LAND;

THENCE; SOUTH 08°35'36" WEST, ALONG THE WEST LINE OF SAID TRACT OF LAND CONVEYED TO CA-AM INVESTMENTS, L.L.C., AT A DISTANCE OF 25.00 FEET, TO A POINT, FOR THE COMMON CORNER OF SAID TRACT OF LAND CONVEYED TO FOR THE COMMON LINE OF LOT 4 AND LOT 5, BLOCK 1, OF SAID NELSON'S ADDITION, CONTINUING TO A DISTANCE OF 75.00 FEET, TO A POINT, FOR THE COMMON LINE OF LOT 5 AND LOT 6, BLOCK 1, OF SAID NELSON'S ADDITION, CONTINUING TO A TOTAL DISTANCE OF 125.00 FEET, TO A POINT, FOR THE SOUTHWEST CORNER OF SAID TRACT OF LAND CONVEYED TO RACHEL REYES, BEING ON THE NORTH RIGHT OF WAY LINE OF ITHICA AVENUE AND THE SOUTH LINE OF LOT 6, BLOCK 1, OF SAID NELSON'S ADDITION, FOR THE SOUTHWEST CORNER OF THIS HEREIN DESCRIBED TRACT OF LAND;

THENCE; NORTH 81°24'24" WEST, ALONG THE NORTH RIGHT OF WAY LINE OF ITHICA AVENUE AND THE SOUTH LINE OF LOT 6, BLOCK 1, OF SAID NELSON'S ADDITION, A DISTANCE OF 50.00 FEET, TO THE POINT OF BEGINNING, CONTAINING A 0.143 (6,250.00 SQ. FT.) OF AN ACRE, MORE OR LESS.

**SURVEY NOTES:**

- BASIS OF BEARING AS PER THE WEST LINE OF LOT 6, BLOCK 1, NELSON'S ADDITION, AS PER THE MAP OR PLAT THEREOF RECORDED IN VOL. 1, PAGE 45, MAP RECORDS OF HIDALGO COUNTY, TEXAS.
- ALL COORDINATES, BEARINGS, AND DISTANCES, ARE BASED ON THE TEXAS COORDINATE SYSTEM, (NAD 83), TEXAS STATE PLANES, SOUTH ZONE (4205) ADJUSTMENT OF 2011, US SURVEY FEET, GRID, BEARINGS AND DISTANCES SHOWN IN PARENTHESIS ARE BASED ON RECORDED DOCUMENT.
- ALL HORIZONTAL CONTROL ON THIS PROJECT WAS ESTABLISHED UTILIZING RTK GPS METHODS.
- THIS SURVEY WAS COMPLETED WITHOUT THE BENEFIT OF AN ABSTRACT OF TITLE. THERE MAY BE EASEMENTS OR OTHER MATTERS THAT ARE NOT SHOWN.

**STATE OF TEXAS  
COUNTY OF HIDALGO**

I, DE LA FUENTE INVESTMENT, LLC, THE UNDERSIGNED, OWNERS OF THE LAND SHOWN ON THIS PLAT AND DESIGNATED HEREIN AS THE **NEW SUBDIVISION** TO THE CITY OF McALLEN, TEXAS, AND WHOSE NAME IS SUBSCRIBED HERETO, HEREBY DEDICATE TO THE USE OF THE PUBLIC ALL STREETS, ALLEYS, PARKS, WATERCOURSES, DRAINS, EASEMENTS, WATER LINES, SEWER LINES, STORM SEWERS, FIRE HYDRANTS AND PUBLIC PLACES WHICH ARE INSTALLED OR WHICH WE WILL CAUSE TO BE INSTALLED THEREON, SHOWN OR NOT SHOWN, IF REQUIRED OTHERWISE TO BE INSTALLED OR DEDICATED UNDER THE SUBDIVISION APPROVAL PROCESS OF THE CITY OF McALLEN, ALL THE SAME FOR THE PURPOSES THEREIN EXPRESSED, EITHER ON THE PLAT HEREOF OR ON THE OFFICIAL MINUTES OF THE APPLICABLE AUTHORITIES OF THE CITY OF McALLEN.

DE LA FUENTE INVESTMENT, LLC  
OSCAR DE LA FUENTE—REGISTERED AGENT  
PRESIDENT

**STATE OF TEXAS  
COUNTY OF HIDALGO**

BEFORE ME, THE UNDERSIGNED AUTHORITY, ON THIS DAY PERSONALLY APPEARED \_\_\_\_\_ OF DE LA FUENTE INVESTMENT, LLC, KNOWN TO ME TO BE THE PERSONS WHOSE NAME IS SUBSCRIBED TO THE FOREGOING INSTRUMENT AND ACKNOWLEDGED TO ME THAT HE EXECUTED THE SAME FOR THE PURPOSE AND CONSIDERATIONS THEREIN STATED.

GIVEN UNDER MY HAND AND SEAL OF OFFICE, THIS THE \_\_\_\_\_ DAY OF \_\_\_\_\_, 20\_\_\_\_.

NOTARY PUBLIC, HIDALGO COUNTY, TEXAS  
MY COMMISSION EXPIRES: \_\_\_\_\_

**HIDALGO COUNTY DRAINAGE DISTRICT NO. 1 CERTIFICATION  
COUNTY OF HIDALGO**

APPROVED BY DRAINAGE DISTRICT:  
HIDALGO COUNTY DRAINAGE DISTRICT NO. 1 HEREBY CERTIFIES THAT THE DRAINAGE PLANS FOR THIS SUBDIVISION COMPLY WITH THE MINIMUM STANDARDS OF THE DISTRICT ADOPTED UNDER TEXAS WATER CODE 49.211(C). THE DISTRICT HAS NOT REVIEWED AND DOES NOT CERTIFY THAT THE DRAINAGE STRUCTURES DESCRIBED ARE APPROPRIATE FOR THE SPECIFIC SUBDIVISION BASED ON THE GENERALLY ACCEPTED ENGINEERING CRITERIA. IT IS THE RESPONSIBILITY OF THE DEVELOPER AND HIS ENGINEER TO MAKE THEIR DETERMINATIONS.

RAUL E. SESIN, P.E., C.F.M.  
GENERAL MANAGER

**STATE OF TEXAS  
COUNTY OF HIDALGO**

I, THE UNDERSIGNED MAYOR OF THE CITY OF McALLEN HEREBY CERTIFY THAT THIS SUBDIVISION PLAT CONFORMS TO ALL REQUIREMENTS OF THE SUBDIVISION REGULATIONS OF THIS CITY WHEREIN MY APPROVAL IS REQUIRED.

MAYOR, CITY OF McALLEN DATE \_\_\_\_\_

CITY CLERK DATE \_\_\_\_\_

**STATE OF TEXAS  
COUNTY OF HIDALGO**

CERTIFICATION BY THE CHAIRMAN OF THE COMMISSION: I, THE UNDERSIGNED, CHAIRMAN OF THE PLANNING AND ZONING COMMISSION OF THE CITY OF McALLEN HEREBY CERTIFY THAT THIS SUBDIVISION PLAT CONFORMS TO ALL REQUIREMENTS OF THE SUBDIVISION REGULATIONS OF THIS CITY WHEREIN MY APPROVAL IS REQUIRED.

CHAIRPERSON, PLANNING AND ZONING COMMISSION DATE \_\_\_\_\_

**STATE OF TEXAS  
COUNTY OF HIDALGO**

I, THE UNDERSIGNED, MARIO ALBERTO GARCIA, A REGISTERED PROFESSIONAL ENGINEER IN THE STATE OF TEXAS, HEREBY CERTIFY THAT PROPER ENGINEERING CONSIDERATION HAS BEEN GIVEN TO THIS PLAT.

MARIO ALBERTO GARCIA, PE NO. 137503 DATE \_\_\_\_\_

**STATE OF TEXAS  
COUNTY OF HIDALGO**

KNOW ALL MEN BY THESE PRESENTS:

I, THE UNDERSIGNED, LEO L. RODRIGUEZ, JR., A REGISTERED PROFESSIONAL ENGINEER AND REGISTERED PROFESSIONAL LAND SURVEYOR IN THE STATE OF TEXAS, HEREBY CERTIFY THAT THIS PLAT IS TRUE AND CORRECTLY MADE AND IS PREPARED FROM AN ACTUAL SURVEY ON THE PROPERTY MADE UNDER MY SUPERVISION ON THE GROUND.

LEO L. RODRIGUEZ, JR., RPLS NO. 2448 DATE \_\_\_\_\_

FILED FOR RECORD IN HIDALGO COUNTY  
ARTURO GUAJARDO JR.  
HIDALGO COUNTY CLERK

ON: \_\_\_\_\_ AT \_\_\_\_\_ AM/PM.

INSTRUMENT NUMBER \_\_\_\_\_  
OF MAP RECORD OF HIDALGO COUNTY TEXAS.  
BY: \_\_\_\_\_ DEPUTY.

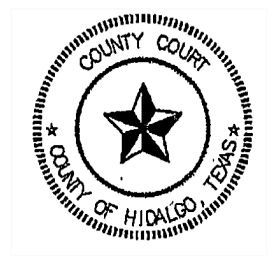

**PRINCIPAL CONTACTS:**

| NAME                                      | ADDRESS                   | CITY & ZIP           | PHONE          | FAX            |
|---|---------------------------|----------------------|----------------|----------------|
| OWNER: DE LA FUENTE INVESTMENTS LLC,      | 520 E NEWPORT LN          | McALLEN, TEXAS 78501 | (956) 330-9277 | NONE           |
| ENGINEER: MARIO ALBERTO GARCIA, P.E.      | 200 S. 10TH ST, STE. 1500 | McALLEN, TEXAS 78501 | (956) 702-8880 | (956) 702-8883 |
| SURVEYOR: LEO L. RODRIGUEZ, JR., R.P.L.S. | 200 S. 10TH ST, STE. 1500 | McALLEN, TEXAS 78501 | (956) 702-8880 | (956) 702-8883 |

DATE OF PREPARATION: October 2024

SHEET 1 OF 3

200 S. 10TH ST. SUITE 1500. TEL. (956) 702-8880  
McALLEN, TEXAS 78501 FAX: (956) 702-8883  
TEX. REG. ENGINEERING FIRM F-10602  
TEX. REG. SURVEYING FIRM No. 101416-00

# NELSON ADDITION LOTS 5A AND 6A SUBDIVISION

## UTILITY LAYOUT

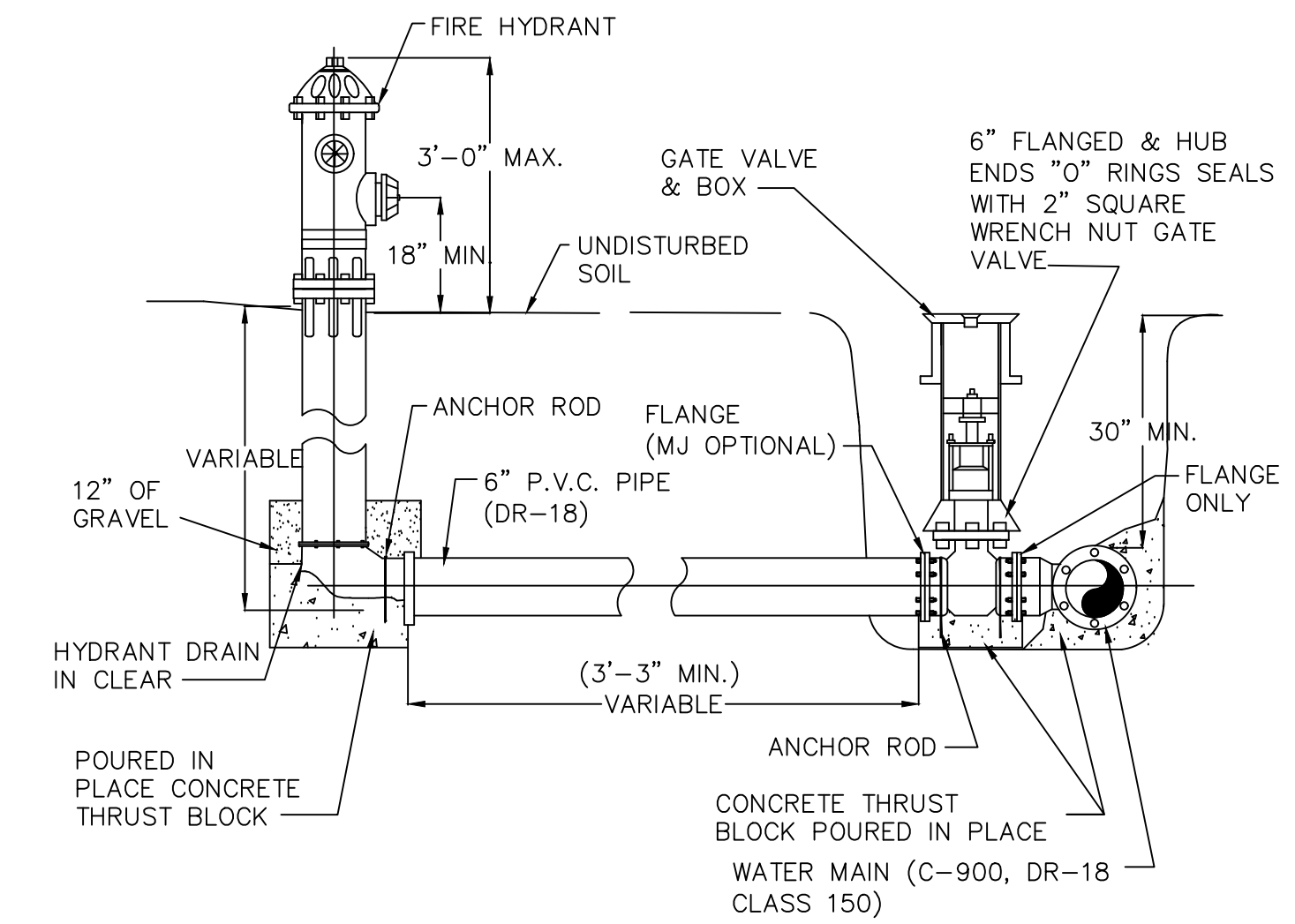
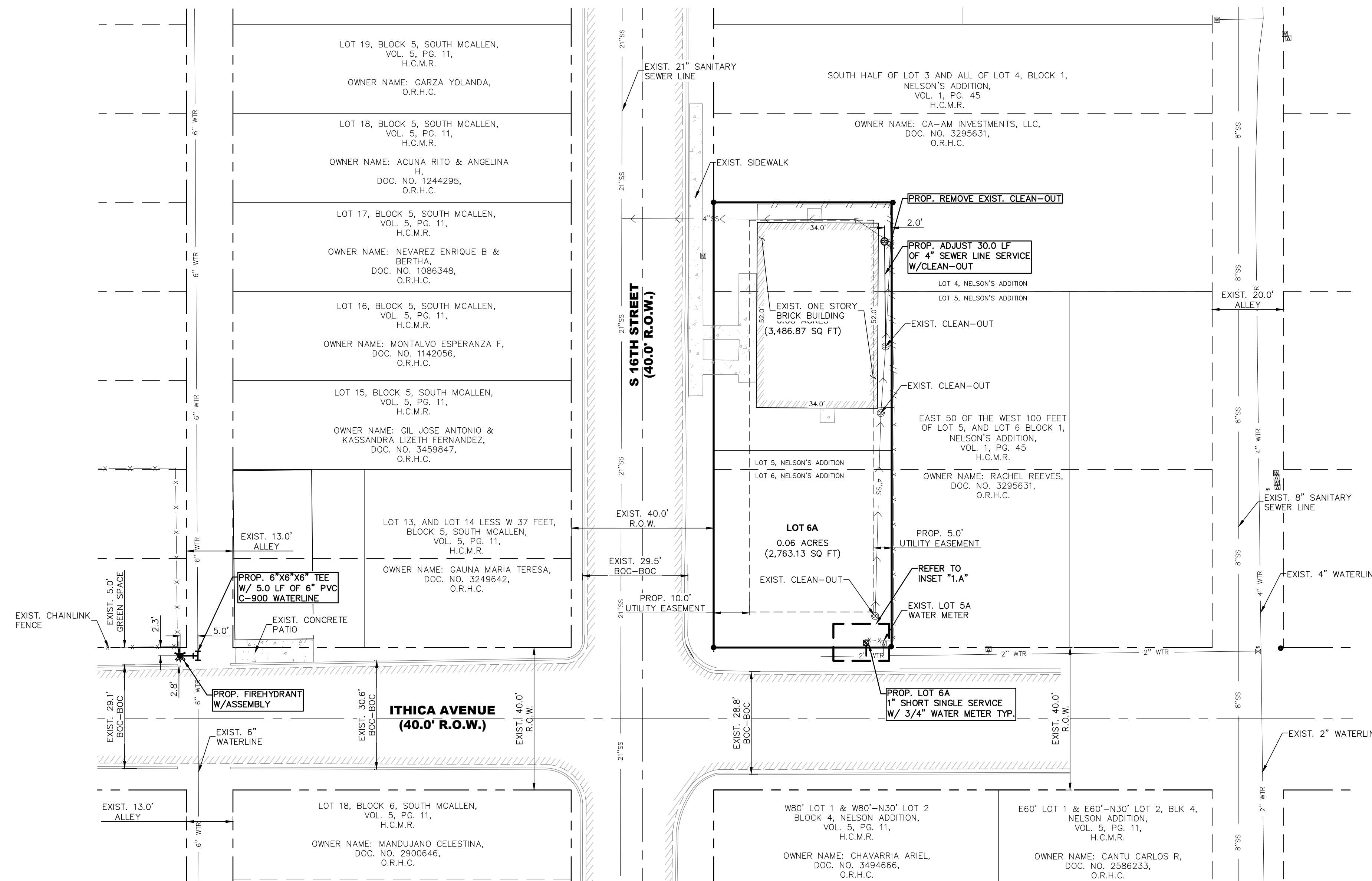
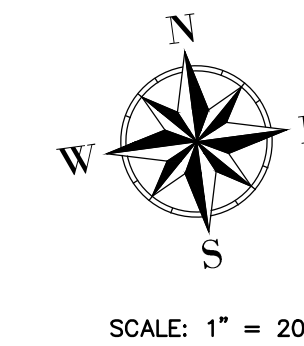

**NOTES:**

1. FIRE HYDRANT ELEVATIONS WILL BE SET BY THE ENGINEER.
2. FLANGE MUST BE AT FINISHED GRADE OR 3" TO 6" ABOVE TOP OF CURB.
3. FLANGED GATE VALVE INSTALLATION TO BE USED WITH 10" WATER LINES OR GREATER.
4. BBF TEES TO BE USED WITH 10" WATER LINE OR GREATER BBF TEES TO BE USED WITH SMALLER DIA. PIPES.
5. ACCEPTABLE HYDRANT BRANDS ARE MUELLER, AMERICAN DARLING AND KENNEDY.

TYPICAL FIRE HYDRANT ASSEMBLY INSTALLATION DETAIL

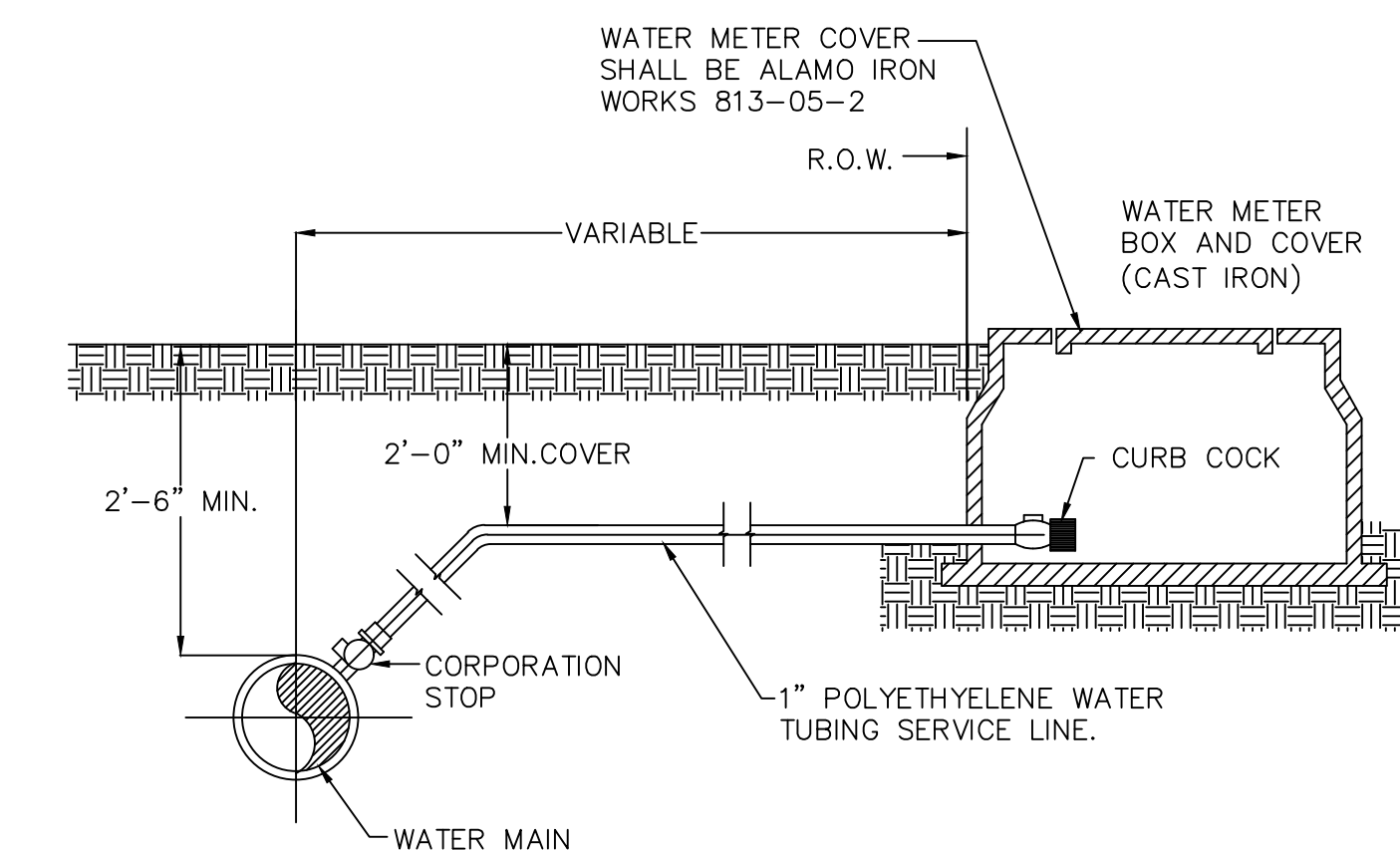

**NOTES:**

1. ALL SERVICE CONNECTIONS NEED TO HAVE A MIN. 2'-0" COVER FROM FINISHED GRADE.
2. WATER METER COVER SHALL BE ALAMO IRON WORKS 813-05-2.
3. ALL WATER MAINS HAVE 30 INCHES OF COVER FROM FINISHED GRADE.
4. METER BOX SHALL BE CAST IRON.
5. ALL CONCRETE TO HAVE A MIN. 28 DAYS COMPRESSIVE STRENGTH OF 3,000 P.S.I.
6. 2" GATE VALVE ONLY REQUIRED FOR 2" SERVICE.
7. POLYETHYLENE TUBING ACCEPTABLE FOR LINE SIZES 1" OR LESS, SCHEDULE 40 PVC REQUIRED FOR LINE SERVICES GREATER THAN 1".

**CONSTRUCTION NOTES:**

- A. WATER VALVE COVER
- B. CURB COCK
- C. METER BOX & METER PROVIDED
- D. WATER TUBING SERVICE LINE
- E. CORPORATION STOP
- F. WATER MAIN

TYPICAL SERVICE CONNECTION WITH METER BOX DETAIL

| ESTIMATED WATER QUANTITIES |  |      |          |
|----------------------------|--|------|----------|
| BID ITEM NO.               | DESCRIPTION                              | UNIT | QUANTITY |
| 1                          | SHORT SINGLE SERVICE W/ 3/4" WATER METER | EA   | 1        |
| 2                          | 6" PVC C-900 WATERLINE                   | LF   | 5        |
| 3                          | FIRE HYDRANT W/ ASSEMBLY                 | EA   | 1        |
| 4                          | 6"X6"X6" TEE                             | EA   | 1        |

| ESTIMATED SANITARY SEWER QUANTITIES |                         |      |          |
|-------------------------------------|-------------------------|------|----------|
| BID ITEM NO.                        | DESCRIPTION             | UNIT | QUANTITY |
| 1                                   | 4" SDR-26 PVC SEWERLINE | LF   | 30       |
| 2                                   | CLEAN-OUT               | EA   | 1        |

**NOTE:**

1. METER BOX TO BE PROVIDED BY DEVELOPER/OWNER.
2. WATER METER TO BE PROVIDED BY THE CITY OF McALLEN.
3. THE CITY OF McALLEN WILL DETERMINE THE SIZE OF WATER METER.
4. ALL WATER SERVICES SHALL BE INSTALLED INSIDE UTILITY EASEMENTS.
5. ALL WATER LINES SERVICES SHALL BE INSTALLED AND RUNNING INSIDE UTILITY EASEMENTS.
6. SANITARY SEWER SERVICES SHALL NOT BE UNDERNEATH FENCES OR ANY STRUCTURES.

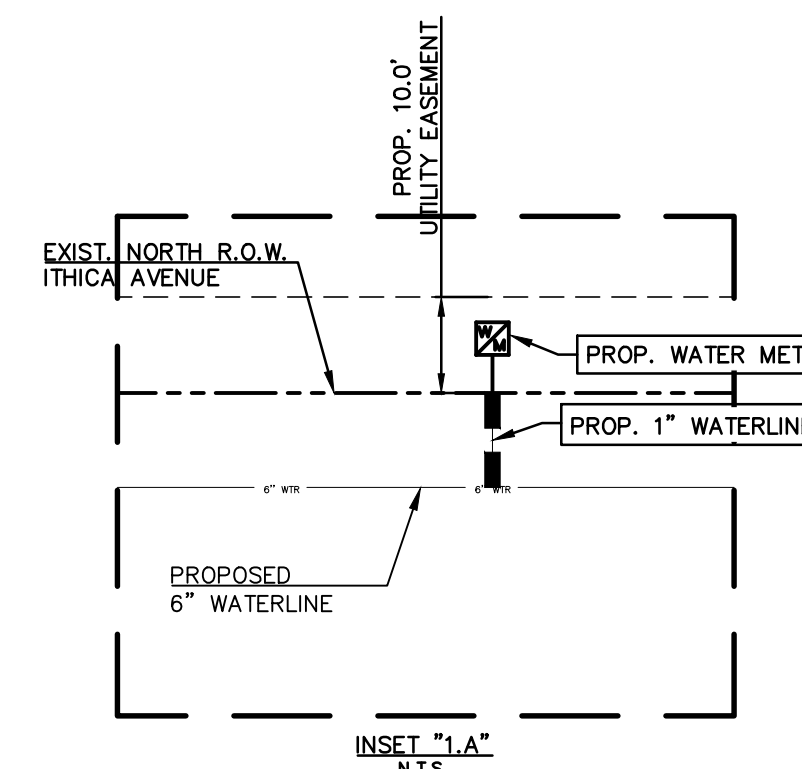

**PRINCIPAL CONTACTS:**

| NAME                                      | ADDRESS                    | CITY & ZIP           | PHONE          | FAX            |
|---|----------------------------|----------------------|----------------|----------------|
| OWNER: DE LA FUENTE INVESTMENTS, LLC.     | 520 E. NEWPORT LN          | McALLEN, TEXAS 78501 | (956) 330-9277 |                |
| ENGINEER: SAUL D. MALDONADO, P.E.         | 200 S. 10TH ST., STE. 1500 | McALLEN, TEXAS 78501 | (956) 702-8880 | (956) 702-8883 |
| SURVEYOR: LEO L. RODRIGUEZ, JR., R.P.L.S. | 200 S. 10TH ST., STE. 1500 | McALLEN, TEXAS 78501 | (956) 702-8880 | (956) 702-8883 |

| NO. | SHEET | REVISION                                   | DATE     | APPROVED |
|-----|-------|--|----------|----------|
| 1   | 2     | ADD FIREHYDRANT AND 6" WATERLINE EXTENSION | 11/1/24  |          |
| 2   | 2     | ADD FIREHYDRANT AND CLEAN-OUT ADJUSTMENT   | 01/09/25 |          |

DATE OF PREPARATION: January 2025

SHEET 2 OF 3

200 S. 10TH ST. SUITE 1500. TEL. (956) 702-8880  
 McALLEN, TEXAS 78501 FAX: (956) 702-8883  
 TEX. REG. ENGINEERING FIRM F-10602  
 TEX. REG. SURVEYING FIRM No. 101416-00

# NELSON ADDITION LOTS 5A & 6A SUBDIVISION

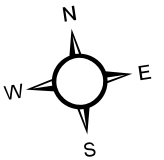

\*UTILITIES SHOWN ARE FOR GENERAL INFORMATION ONLY AND MAY NOT BE 100% ACCURATE. UTILITIES SHOULD BE FIELD VERIFIED PRIOR TO DESIGN OR CONSTRUCTION.



**Legend**

- Prop Hydrants
- Prop Sewerlines
- Prop Waterlines
- Water Valve
- Reclaimed Water
- Water Lines**
- Potable
- Raw Water, Active
- Reclaimed Water
- GISDATA.SDE.SSManholes
- Sewer Lines**
- Force Main
- Gravity



AGENDA ITEM 3.a.

PUBLIC UTILITY BOARD

DATE SUBMITTED 02/05/2025

MEETING DATE 2/11/2025

1. Agenda Item: Order amending the budget of the McAllen Public Utility Board of Trustees for Fiscal Year 2024-2025 for an increase in expenditures within the Water Depreciation Fund.

2. Party Making Request:  
Mark Vega, General Manager

3. Nature of Request: Order amending the budget of the McAllen Public Utility Board of Trustees for Fiscal Year 2024-2025 for an increase in expenditures within the Water Depreciation Fund totaling \$13,700 for the purchase of vehicles.

4. Budgeted:

|               |       |                   |       |
|---------------|-------|-------------------|-------|
| Bid Amount:   | _____ | Budgeted Amount:  | _____ |
| Under Budget: | _____ | Over Budget:      | _____ |
|               |       | Amount Remaining: | _____ |

5. Reimbursement:

6. Routing:  
Maria Chavero Created/Initiated - 2/5/2025

7. Staff's Recommendation: Staff Recommends Approval

8. City Attorney: Approve. AWS

9. MPU General Manager: Approved - MAV

10. Director of Finance for Utilities: Approved - MSC

AN ORDER AMENDING THE BUDGET OF THE McALLEN PUBLIC UTILITY BOARD OF TRUSTEES FOR THE FISCAL YEAR 2024/2025 EFFECTIVE OCTOBER 1, 2024, BY PROVIDING FOR AN INCREASE IN EXPENDITURES TO-WIT: \$13,700 WITHIN THE WATER DEPRECIATION FUND FOR THE PURCHASE OF VEHICLES AND PROVIDING FOR AN EFFECTIVE DATE.

WHEREAS, the McAllen Public Utility Board of Trustees of the City of McAllen, Texas annually adopts its budget and submits to the City Commission which incorporates such budget in the overall budget for the City by ordinance.

WHEREAS, McAllen Public Utility Board of Trustees by ordinance of the City Commission providing for the creation of the McAllen Public Utility Board of Trustees, has the authority to manage and control the McAllen Public Utility, including control over fiscal matters of the Public Utility Board and therefore, it is not necessary that the City Commission approve the budget of the McAllen Public Utility Board of Trustees, and henceforth the McAllen Public Utility Board of Trustees will approve its budget and all amendments thereto by order which shall be filed along with the City Budget under the provisions of the Local Government Code.

NOW, THEREFORE, BE IT ORDAINED BY THE MCALLEN PUBLIC UTILITY BOARD OF TRUSTEES OF THE CITY OF McALLEN, TEXAS, THAT:

SECTION I: The Budget for the McAllen Public Utility Board of Trustees for the Fiscal Year 2024/2025 which became effective October 1, 2024, on file with the Board's Secretary, is hereby amended in the following particulars as shown on Exhibit "A" attached hereto and incorporated herein for all purposes.

SECTION II: The General Manager as Budget Officer shall provide for the filing of a true copy of this Budget Amendment in the office of the County Clerk, Hidalgo County, Texas.

SECTION III: This Order shall be effective after its passage and execution in accordance with the law.

SECTION VI: If any part or parts of this Order are found to be invalid or unconstitutional by a court having competent jurisdiction, then such invalidity or unconstitutionality shall not affect the remaining parts hereof and such remaining parts shall remain in full force and effect, and to that extent this Order is considered severable.

CONSIDERED, PASSED and APPROVED this 11<sup>th</sup> day of February 2025, at a meeting of the of the McAllen Public Utility Board of Trustees of the City of McAllen, Texas, at which a quorum was present, and which was held in accordance with Chapter 551 of the Texas Government Code.

SIGNED this \_\_\_\_\_ day of February 11, 2025.

McALLEN PUBLIC UTILITY  
BOARD OF TRUSTEES

By: \_\_\_\_\_  
Charles Amos, Chairman

ATTEST:

By: \_\_\_\_\_  
Cynthia Salinas, Board Secretary

APPROVED AS TO FORM:

\_\_\_\_\_  
Austin Stevenson, City Attorney



**BUDGET AMENDMENT REQUEST FORM**

**FUND:** Water Depreciation  
**DEPARTMENT:** Water Administration/Capital Outlay -Vehicles  
**FISCAL YEAR:** 2024-2025

|   |       |
|---|-------|
| <b>To be assigned by Treasury Management Dept.</b>              |       |
| <b>REVIEW BY</b>  | _____ |
| <b>DATE OF ENTRY</b>  | _____ |
| <b>ENTRY MADE BY</b>  | _____ |
| <b>JOURNAL ENTRY</b>  | _____ |
| <b>ORDINANCE NO.</b>  | _____ |
| <b>INTRANET CROSS FUND CAPITAL IMPRV PROJECT LISTING UPDATE</b> | _____ |

| Fund          | Dept. & Division | Activity | Element & Object | Project Code | Description               | Original/Revised Budget | Debit/Credit     | Revised Budget   |
|---------------|------------------|----------|------------------|--------------|---------------------------|-------------------------|------------------|------------------|
| 410           | 4060             | 446      | 66-14            |              | Capital outlay / Vehicles | \$ 42,000               | \$ 13,700        | \$ 55,700        |
|               |                  |          |                  |              |                           |                         |                  |                  |
|               |                  |          |                  |              |                           |                         |                  |                  |
|               |                  |          |                  |              |                           |                         |                  |                  |
| <b>TOTALS</b> |                  |          |                  |              |                           | <b>\$ 42,000</b>        | <b>\$ 13,700</b> | <b>\$ 55,700</b> |

(Round up all amounts to the nearest hundred dollars)

**JUSTIFICATION:**

Vehicle costs came in at \$13,700 over the budgeted amount of \$42,000.

|                                  |             |
|----------------------------------|-------------|
| <b>General Manager</b>           |             |
| _____                            | _____       |
| <b>Signature</b>                 | <b>Date</b> |
| <b>Treasury Management Dept.</b> |             |
| _____                            | _____       |
| <b>Signature</b>                 | <b>Date</b> |
| <b>Department Head</b>           |             |
| _____                            | _____       |
| <b>Signature</b>                 | <b>Date</b> |



|                             |                       |                    |
|-----------------------------|-----------------------|--------------------|
|                             | <b>AGENDA ITEM</b>    | <b><u>4.a.</u></b> |
| <b>PUBLIC UTILITY BOARD</b> | <b>DATE SUBMITTED</b> | <b>01/29/2025</b>  |
|                             | <b>MEETING DATE</b>   | <b>2/11/2025</b>   |

1. Agenda Item: Consideration and Possible Action to write-off the 3rd quarter bad debt fiscal year 2023-2024.
2. Party Making Request:  
Pablo Rodriguez, Customer Relations Manager
3. Nature of Request: Authorization to write off bad debt: Water fund \$11,345.24 Sewer Fund \$8,833.83 for a total write-off of \$20,179.07.
4. Budgeted:

|               |       |                   |       |
|---------------|-------|-------------------|-------|
| Bid Amount:   | _____ | Budgeted Amount:  | _____ |
| Under Budget: | _____ | Over Budget:      | _____ |
|               |       | Amount Remaining: | _____ |
5. Reimbursement:
6. Routing:  
Pablo Rodriguez                      Created/Initiated - 1/29/2025
7. Staff's Recommendation: Approval of \$20,179.07.
8. City Attorney: Approve. AWS
9. MPU General Manager: Approved - MAV
10. Director of Finance for Utilities: Approved - MSC

# Memo

**To:** Mark Vega, General Manager  
**From:** Pablo M. Rodriguez, Assistant Director –Customer Relations  
**Thru:** Maria Chavero, Director of Finance for Utilities  
**Date:** 1/29/2025  
**Re:** Bad Debt write-offs for 3<sup>rd</sup> Quarter FY 2023-2024

Attached for your review and consideration is a list of delinquent accounts for the 3rd Quarter of FY 2023-2024 (April 1, 2024-June 30, 2024). Staff is recommending approval of the bad debt write-off for \$20,179.07 which constitutes 0.18% of collected revenues for same period. Billed revenues totaled \$11,276,185.70. The breakdown for the proposed bad debt write-off is illustrated below:

**By Fund:**

| Fund         | 3rd Qtr FY 2023-2024 Revenues | Amount of Write-Off | Percent of Revenues |
|--------------|-------------------------------|---------------------|---------------------|
| Water        | \$6,385,081.94                | \$11,345.24         | 0.10%               |
| Sewer        | \$4,891,103.76                | \$8,833.83          | 0.08%               |
| <b>Total</b> | <b>\$11,276,185.70</b>        | <b>\$20,179.07</b>  | <b>0.18%</b>        |

**By customer type:**

| Type         | No. of Accounts | Amount of Write-Off | Percent of Write-Off | Percent of Revenues |
|--------------|-----------------|---------------------|----------------------|---------------------|
| Rental       | 214             | \$15,583.16         | 77.22%               | 0.14%               |
| Owned        | 78              | \$4,595.91          | 22.78%               | 0.04%               |
| <b>Total</b> | <b>292</b>      | <b>\$20,179.07</b>  | <b>100.00%</b>       | <b>0.18%</b>        |

**By customer class:**

| Water & Sewer | Amount of Write-Off | Percent of Write-Off | Percent of Revenues |
|---------------|---------------------|----------------------|---------------------|
| Residential   | \$18,199.60         | 90.19%               | 0.16%               |
| Commercial    | \$1,903.77          | 9.43%                | 0.02%               |
| Multi-Family  | \$75.70             | 0.38%                | 0.00%               |
| <b>Total</b>  | <b>\$20,179.07</b>  | <b>100.00%</b>       | <b>0.18%</b>        |



**City of McAllen**  
**McAllen Public Utility**

**Bad Debt Write-Off Report for**  
**3<sup>rd</sup> Quarter FY 2023-2024**

# ACCOUNTS BREAKDOWN

- ▶ 292 Accounts on Report  
\$20,179.07.
- ▶ 247 Accounts have  
balances less than  
\$100.00.
- ▶ 45 Accounts have  
balances greater than  
\$100.00.

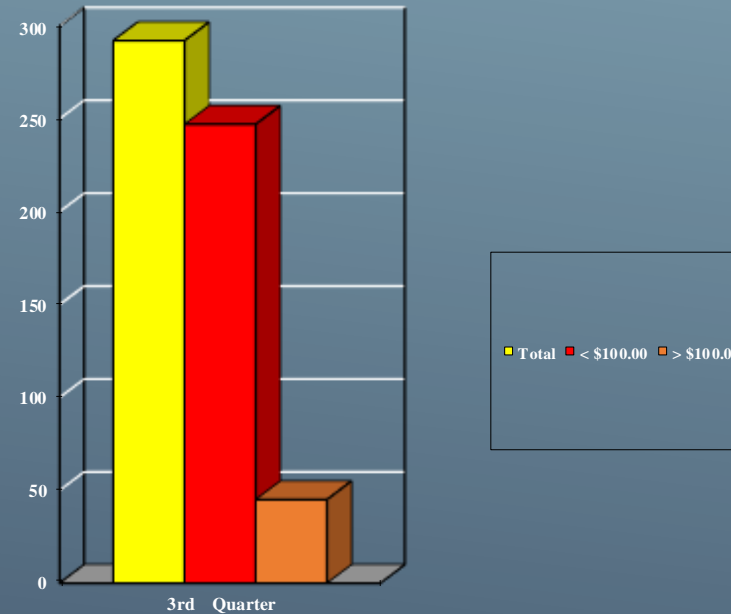

# BY FUND TOTALS

- ▶ Total \$20,179.07
- ▶ Water - \$11,345.24
- ▶ Sewer - \$8,833.83
- ▶ Combined they represent .18% of 3<sup>rd</sup> Qtr. Revenues

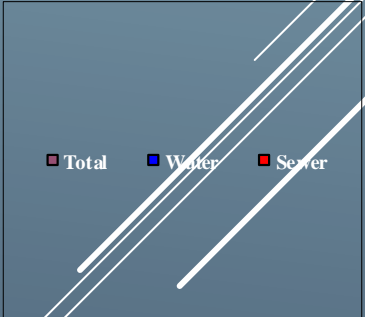
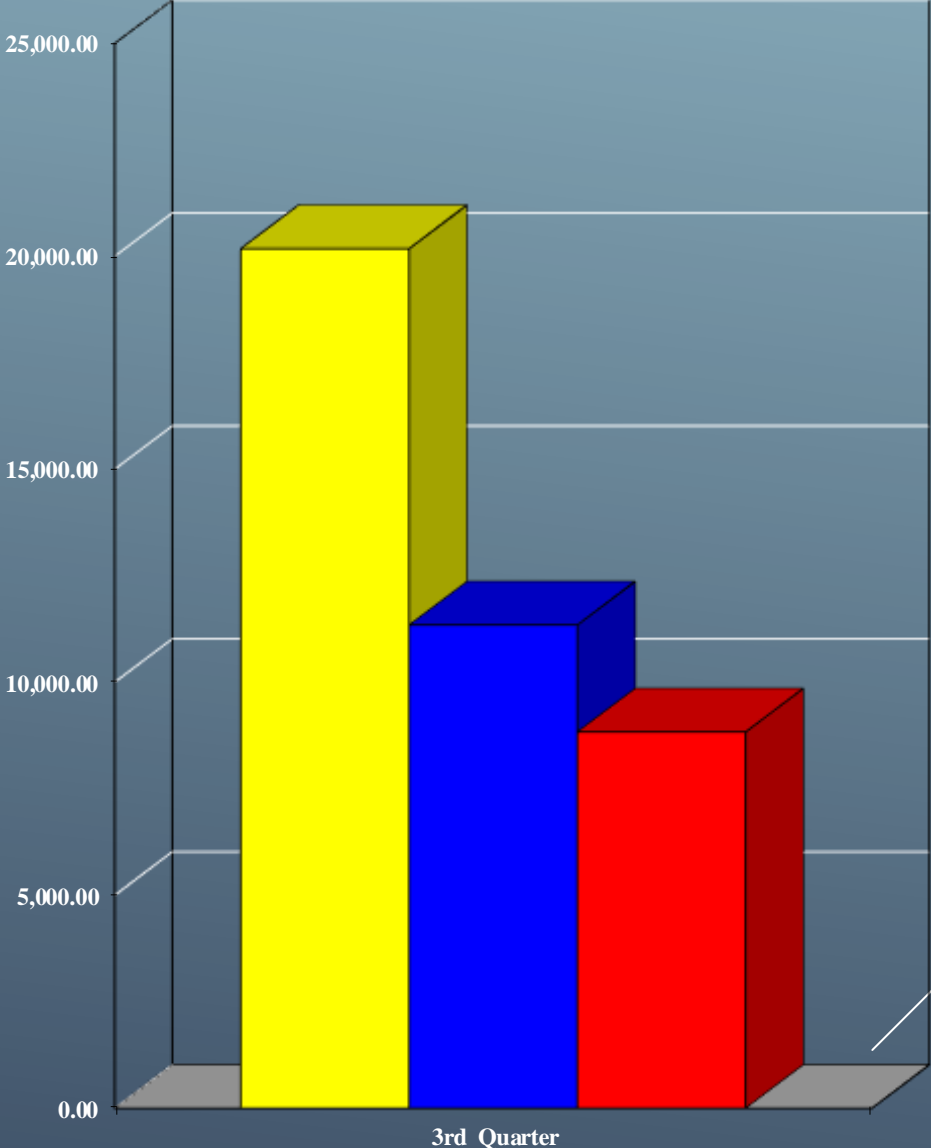

# BY CUSTOMER CLASS

- ▶ Total - \$20,179.07
- ▶ Residential - \$18,199.60
- ▶ Commercial - \$1,903.77
- ▶ Multi-Family - \$75.70

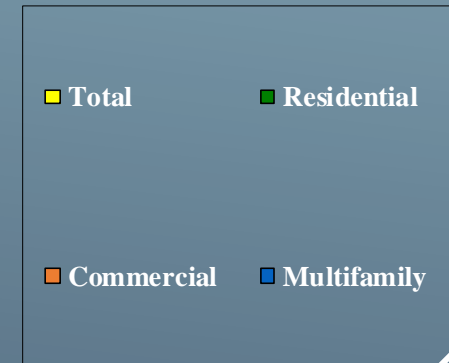
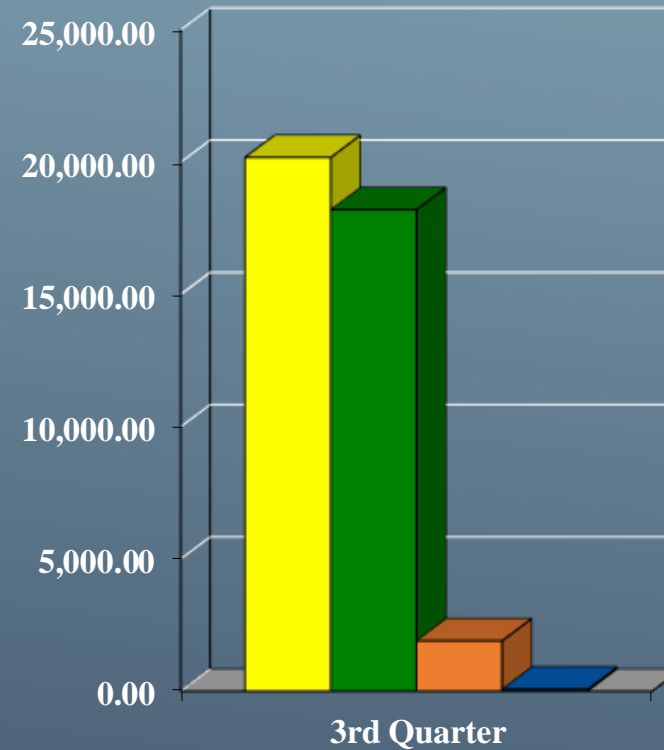

# BY CUSTOMER TYPE

- ▶ Total - \$20,179.07
- ▶ Rental - \$15,583.16
- ▶ Owner - \$4,595.91

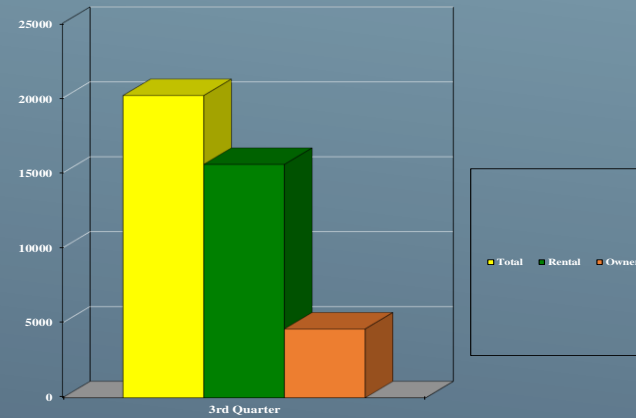

# ACCOUNTS WITH \$100.00 PLUS BALANCES SUMMARY.

- ▶ Of the 292 accounts on the list, 45 have balances greater than \$100.00
  - ▶ Accounts had a deposit and deposit was applied to the account.
  - ▶ Collection efforts are continuous.
- 

# PROPOSAL

- ▶ 3rd Quarter Bad Debt Write-Off –  
\$20,179.07 / .18% of Revenues for same period.
  - ▶ Staff recommends approval of bad debt write-off for this period by the Board.
  - ▶ Thank You!
- 



**City of McAllen**  
**McAllen Public Utility**

**Trend Analysis of Bad Debt**  
**3rd Quarter**



# TREND ANALYSIS OF BAD DEBT

- ▶ 2020-2021 - .12%
- ▶ 2021-2022 - .19%
- ▶ 2022-2023 - .25%
- ▶ 2023-2024 - .18%

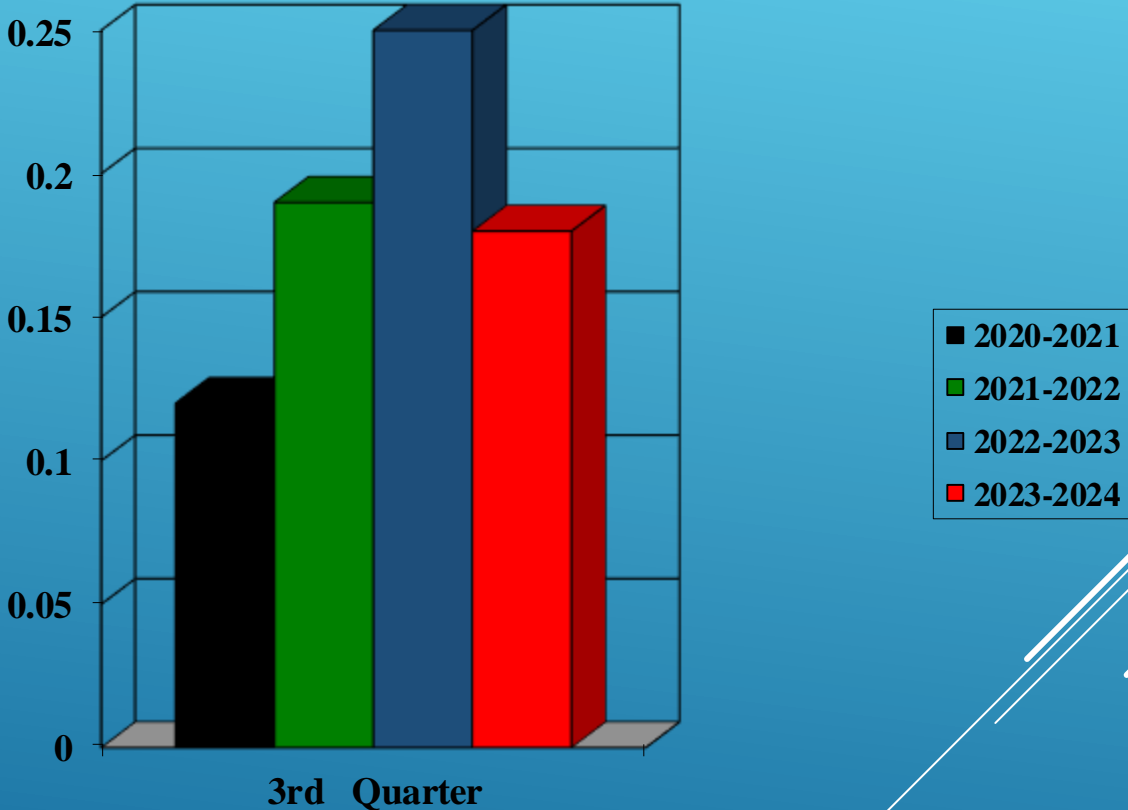



**City of McAllen**  
**McAllen Public Utility**

**Trend Analysis of Bad Debt**  
**Last Four Quarters**

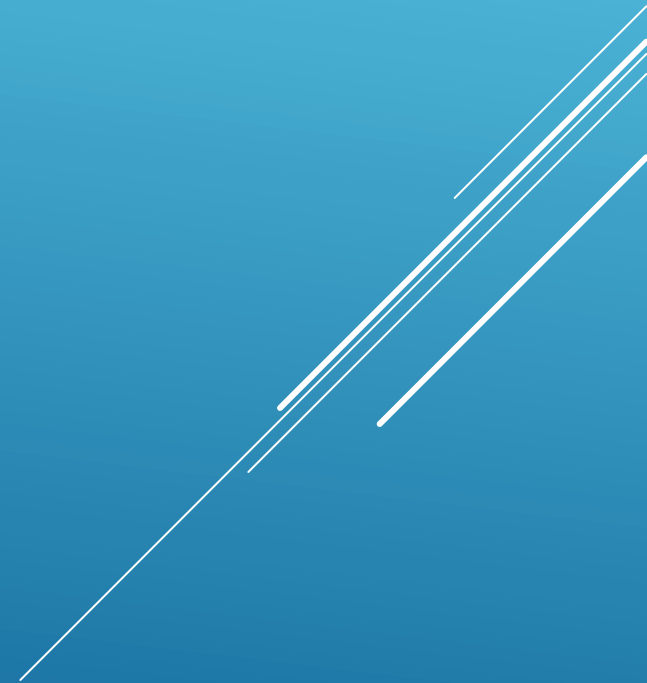

# TREND ANALYSIS OF BAD DEBT

- ▶ 4th Qtr 22-23 .25%
- ▶ 1st Qtr 23-24 .23%
- ▶ 2nd Qtr 23-24 .30%
- ▶ 3rd Qtr 23-24 .18%

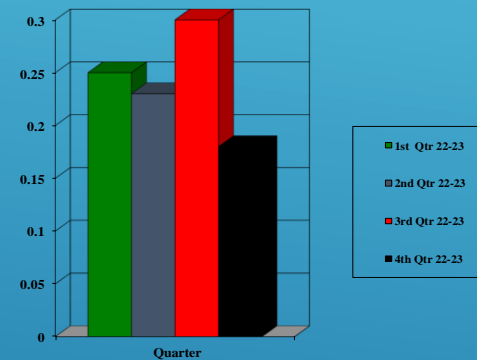



|                             |                       |                    |
|-----------------------------|-----------------------|--------------------|
|                             | <b>AGENDA ITEM</b>    | <b><u>6.a.</u></b> |
| <b>PUBLIC UTILITY BOARD</b> | <b>DATE SUBMITTED</b> | <b>02/03/2025</b>  |
|                             | <b>MEETING DATE</b>   | <b>2/11/2025</b>   |

1. Agenda Item: Consultation with City Attorney regarding pending litigation Tex. Gov't Code Sec. 551.071

2. Party Making Request:

3. Nature of Request:

4. Budgeted:

|                      |       |                          |       |
|----------------------|-------|--------------------------|-------|
| <b>Bid Amount:</b>   | _____ | <b>Budgeted Amount:</b>  | _____ |
| <b>Under Budget:</b> | _____ | <b>Over Budget:</b>      | _____ |
|                      |       | <b>Amount Remaining:</b> | _____ |

5. Reimbursement:

6. Routing:  
Savannah Arredondo                      Created/Initiated - 2/3/2025

7. Staff's Recommendation:

8. City Attorney: None. AWS

9. MPU General Manager: N/A - MAV

10. Director of Finance for Utilities: N/A - MSC